

**MOUNTING INSTRUCTIONS FOR M247
AIR POWERED DRAWBAR**



Specifications

Power Requirement	24V
Air Pressure Requirement	90psi
Speed	3000 RPM
Torque	135 ft/lbs

Drawbar Assembly

The goal of these procedures is to fabricate an entirely new drawbar that will extend down through the spindle the same length as your mill's existing drawbar. Also, you must ensure that the top shoulder of the new bolt head will be flush with the mounting surface of the motor assembly

To assemble the drawbar:

1. Use a caliper to measure the diameter of your milling machine drawbar bolt head (Fig.2)

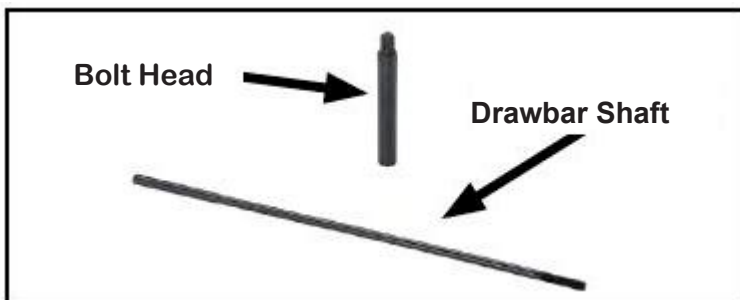



Figure 2. Bolt head and drawbar shaft.

NT40
Reduce the diameter of the new bolt head to match the diameter of the existing drawbar head



Existing



New

Fig.3

If the diameter of your mill's existing bolt head is 24mm, then proceed to Step 2.

If your existing drawbar is an NT40, use a lathe to turn the new bolt head to match the diameter of the your mill's existing bolt head (see A in Figure 3).

Note: The splines of the new bolt head are specifically designed to match the socket of the drawbar motor. DO NOT damage them.

Note: Before making any alterations to the new drawbar, read through the rest of the instructions to calculate the correct lengths.

If your existing drawbar is a two piece drawbar then you must build a drawbar motor mounting extension ring that will allow only the full spline to be above the mounting surface (see Figure 4).

2. Measure the length of your mill's existing drawbar from the bottom of the bolt head to the end of the drawbar shaft, then add 38mm (see Figure 5).

Note: The additional 38mm is the amount of the new shaft that will be inserted into the new bolt head in a later step.

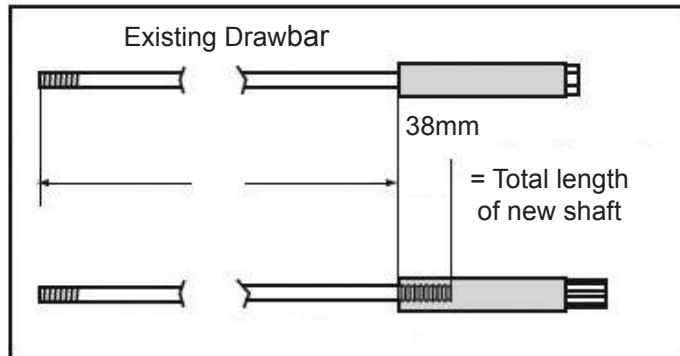

Figure 5. Calculating the length of the new shaft.

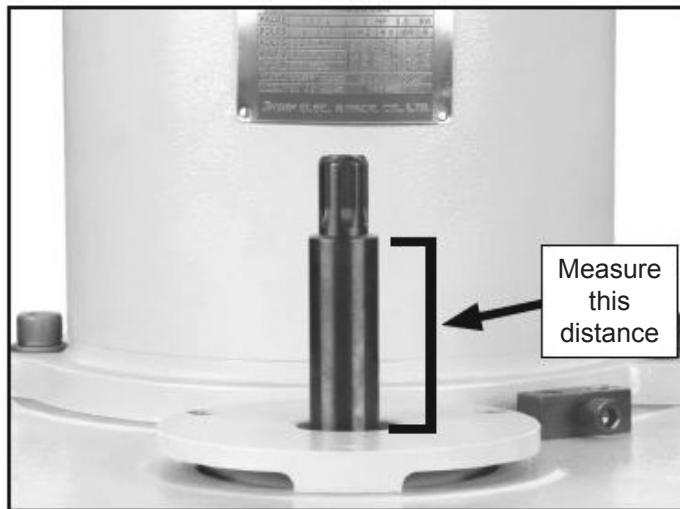

Figure 6. Checking the measurement

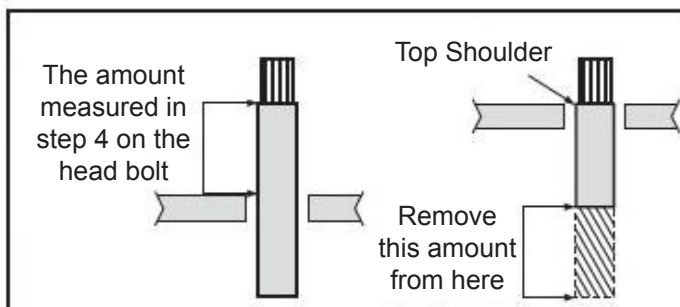

Figure 7. Measuring the amount of the new drawbar head bolt to remove.

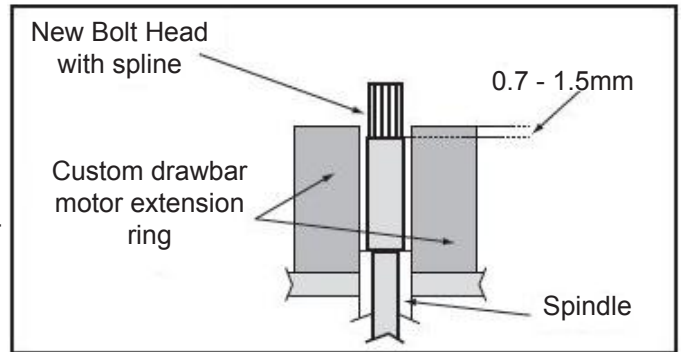

Figure 4. Example a custom drawbar motor extension ring

3. Remove the necessary amount, if any, from the top of the new drawbar shaft to make the total length of the shaft equal to the total length calculated in Step 2, then turn threads into the last 38mm

4. Insert the new bolt head into the top of the spindle, then measure the distance from the top shoulder of the bolt head to the mounting surface of the motor assembly (see Figure 6).

5. Remove the amount measured in Step 4 from the bottom of the new bolt head (see Figure 7).

Note: The top shoulder of the new bolt head below the spline must be 0.7—1.5mm below the mounting surface on the mill to properly engage with the drawbar motor.

6. Drill and tap 45mm into the bottom of the new bolt head with threading to match the top of the new drawbar shaft from Step 3.

7. Thread the new drawbar shaft into the bottom of the new bolt head, as shown in Figure 8.

Note: We recommend the addition of four M5-.8 x 10 set screws applied through the bolt head to further secure the drawbar shaft, as shown in Figure 8.

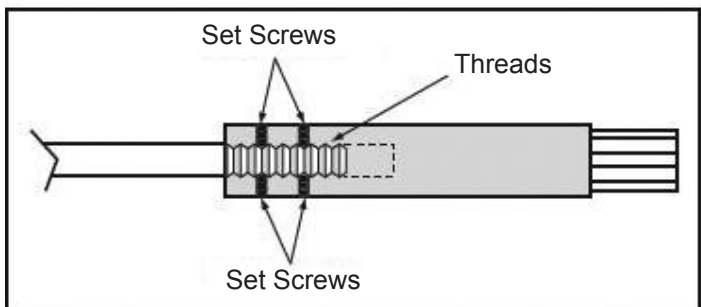

Figure 8. Example of new drawbar.

Installation

1. Prepare the top of your mill so that the mounting plate of the power drawbar motor is center-aligned to the spindle.

2. If the mounting holes in the motor mounting plate do not align with threaded holes in the mill to accept the three M6-1 x 20 cap screws and lock washers, drill new holes in the motor mounting plate.

Note! The pneumatic motor must be mounted flat with and fully supported by the mill, and exactly centered over the spindle opening.

3. Insert the new drawbar assembly, then mount and secure the pneumatic motor to the mill.

4. Select a spot on your mill to mount the pneumatic control box and switch so that the air hoses can reach the pneumatic motor and the switch can be connected to a grounded 24V power source.

5. Connect the three air hoses to the pneumatic motor, as shown in Figures 9-10.

Note: The two smaller air hoses are numbered "1" and "2" and must be inserted into the corresponding connectors. To insert the air hoses, simply push them into the self sealing gaskets. To remove an air hose, push the black self-sealing gasket in while pulling the air hose out.

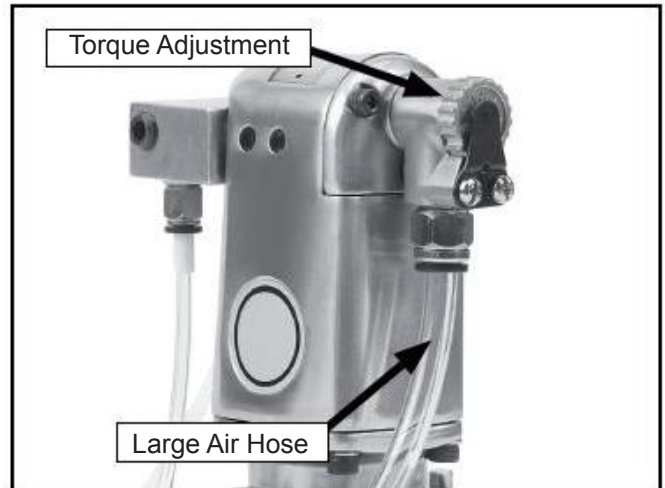

Figure 10. Large air hose installed into the pneumatic motor.

Set the motor torque adjustment shown in Figure 10 between "5" and "8".

Note: A torque adjustment setting of "5" provides the least amount of operational torque to the drawbar, and "8" provides the highest.

7. Mount the air regulator unit on your mill so that the included air hose will connect this unit to the pneumatic control box (see Figure 11).

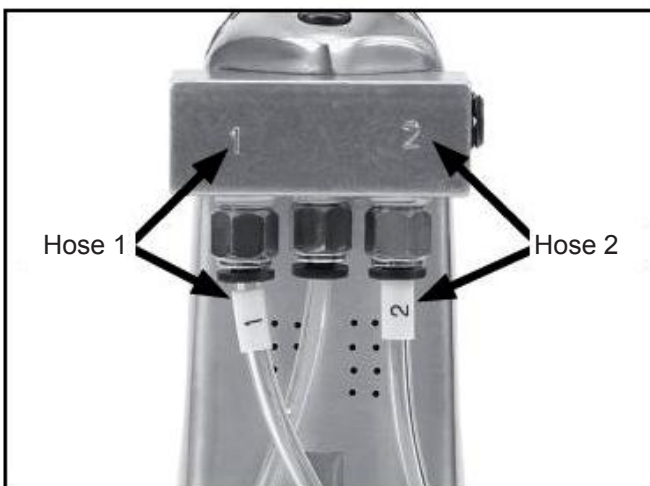

Figure 9. Smaller air hoses installed into the pneumatic motor.

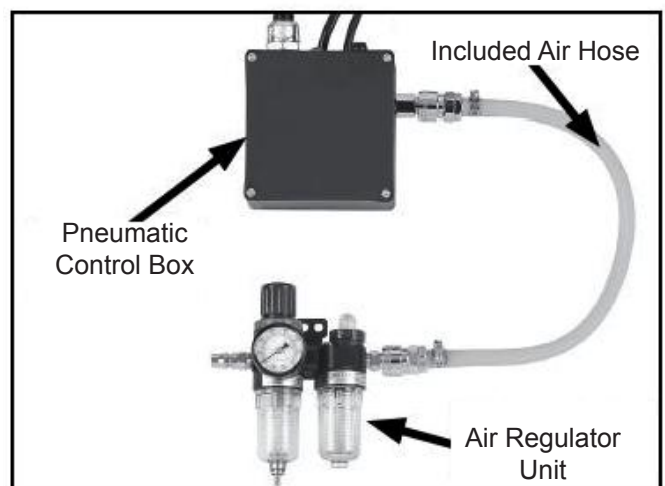

Figure 11. Example of the air regulator unit connected to the pneumatic control box.

8. Connect the power to the machine's power supply (An authorized electrician should be used).

9. Fill the lubrication cup of the air regulator unit with standard pneumatic tool oil.

10. Connect the inlet valve to clean, dry compressed air of 90—120 PSI.

11. Pull the air pressure adjustment knob up, then turn it until the pressure gauge reads 90 PSI.