

**TOOLMASTER G198
TOOL & CUTTER
GRINDER
MANUAL**

PREFACE

This manual is the operation and maintenance instructions of the G198 Toolmaster tool and cutter grinder. Please put this manual in a place where the operator can easily find it for quick reference. The operator should fully understand the instructions in this manual so that trouble free continuous operation can be obtained.

All the drawings and pictures in this manual are only used for description. Dimension, accuracy or other details are given for an example. According to our continuous improvements and our product policy, we reserve the right to change the machine specifications and designs without notice. Our machine and accessories are covered for 12 months against any materials or manufacturing defect. If the defect is due to abnormal operation or misunderstanding operation methods, then it is beyond this guarantee.

Upon receiving the G198 machine, please check all the parts and accessories according to packing list. If there are any shortages or damage, please report to us immediately. If there is any complaint or service required, it must be accompanied with the machine serial number.

CONTENT

1. Location and Lifting
 - 1-1 Location
 - 1-2 Lifting
2. Main Structure Introduction
3. General Specification
 - 3-1 Dimensional drawing
 - 3-2 Main Specification
 - 3-3 Design feature
4. Operating Instruction
 - 4-1 Mounting Grinding Wheel
 - 4-2 Wheel Dressing :
 - 4-3 Cutting Tool Instruction
 - 4-4 Basic setting for the cutter grinding
 - 4-5 End Milling Cutter Outer Flute
 - 4-6 Cutter End Side Grinding
5. Dividing Attachment
6. Drill Sharpener
7. Parts List

1. Location and Lifting

1-1 Location

It is recommended to locate this machine if possible in a position with constant temperature (about 20 °C) and is not recommended in a position that is damp, or near chemical gas or vibration. The machine should not be exposed to constant sunlight, rain, or operated in a potential explosive environment.

1-2 Lifting

The use of web slings is recommended. Move the saddle to the back position and lock the saddle before lifting. Remove the motorized workhead and restrict the table travel so that it cannot move. Lower the head and place a block of wood between the head and the table to insure that the table does not lift during lifting.

Use the lifting web slings for lifting as below, with one sling under the cross slide and the other around the column. Adjust the slings until the machine is level. (the net weight of machine is 212kg)

Cautions when lifting:

- (1) Lift the machine with the slowest speed of crane.
- (2) Retaining the machine balance during the lifting. Put the machine down carefully and slowly to the desired location.
- (3) During lifting, please insure that no one stands beneath machine. Keep people away from the dangerous zone at least two meters.

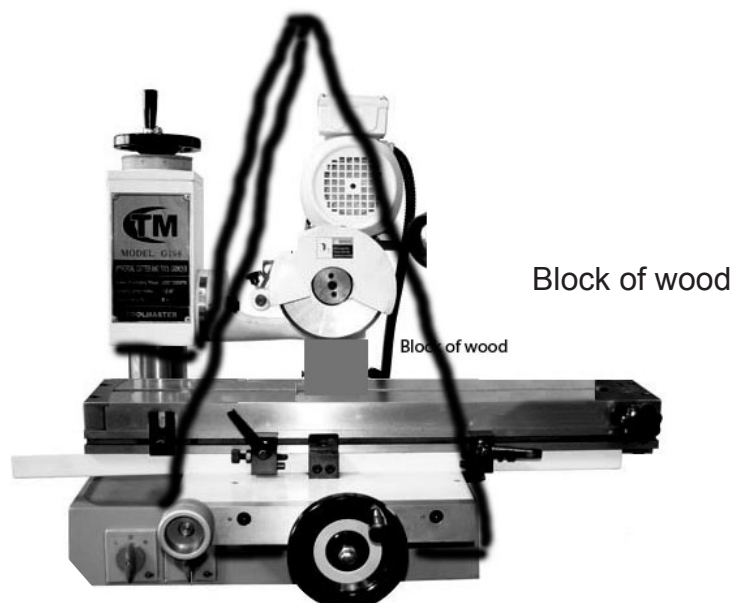

MAIN STRUCTURE INTRODUCTION

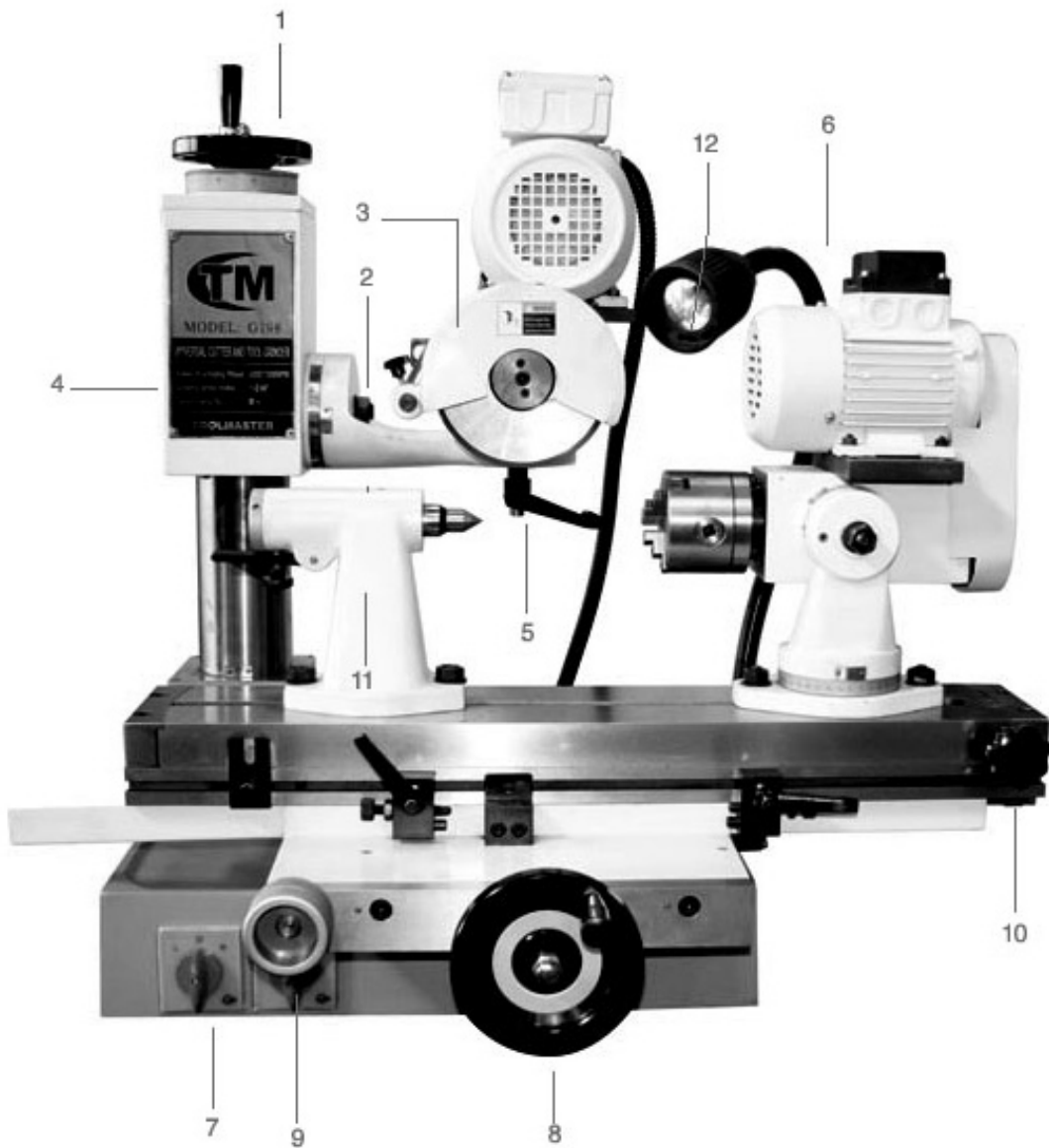

1. Elevating handwheel
2. Wheel head tilt clamp.
3. Super-Precision motor spindle assembly.
4. Vertical locking screw.
5. Wheel head setting lever.
6. Motorized workhead
7. Forward and reverse switches.
8. Cross feed handwheel
9. Longitudinal handwheel
10. Table Taper adjustment
11. Tailstock
12. Work light

3. GENERAL SPECIFICATION

I, Parameters

| | |
|---|----------------------------|
| 1. Max. Grinding Diameter | 250mm |
| 2. Grinding Length | 400mm |
| 3. Lifting Height Of Grinding Wheel | 150mm |
| 4. Rotating Angle Of Grinding Wheel | 360 °(Vertical/Horizontal) |
| 5. Lateral Feeding Distance | 190mm |
| 6. Dimension Of Grinding Wheel (DxHxd) | 150x50x32mm |
| 7. Max. RPM of Grinding Wheel | 5000rpm |
| 8. Motor For Grinding Wheel 0,55KW(314HP) | 220V/60HZ/3Hp 3600RPM |
| 9. Motor For Head Folder | 90watts 220V 1400rpm |
| 10.Total Power | 0.64Kw |
| 11. Weight Of The Machine | 222kg Gross Net 209kg |
| 12. Dimensions of Machine (LxWxH) | 870x730x810mm |
| 13. Package Dimensions (LxWxH) | 730x710x715mm |

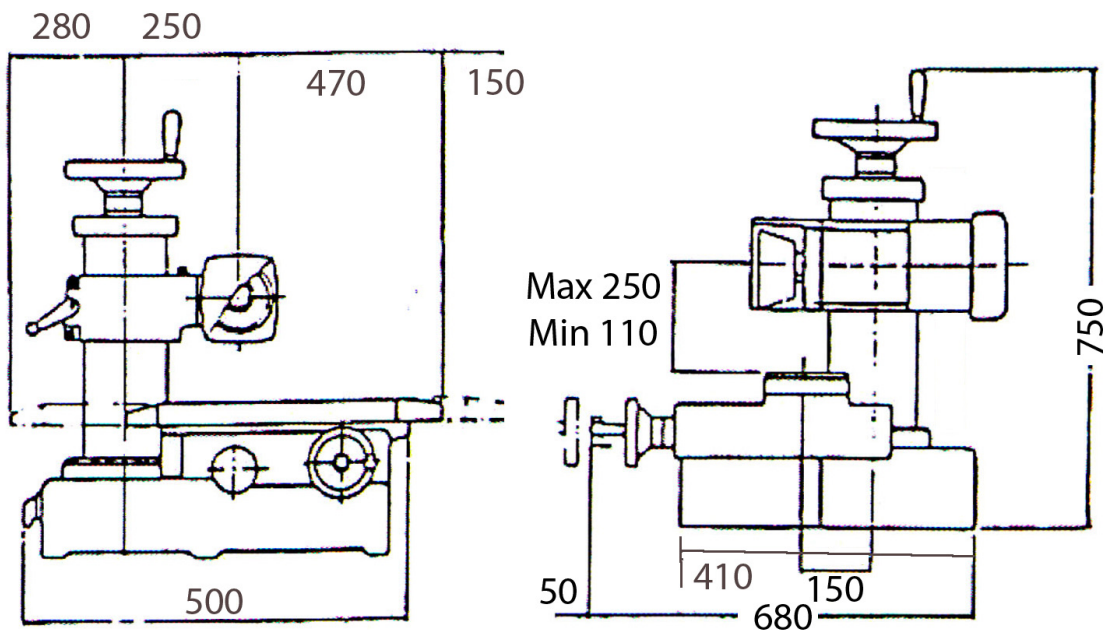

GENERAL SPECIFICATION

- (1) 3-3 Designing Features
- (2) Working table is mounted on a high precision linear ball slide to insure smooth operation.
- (3) The motor can rotate 360 degrees
- (4) Motorised work head can be used in either forward or reverse mode
- (5) Precision acme screw thread to adjust the head 160mm up-down.
- (6) The machine is manufactured from Fc30 Cast iron.
- (7) The column can adjust to 360 °

OPERATING INSTRUCTION

4-1 Mounting The Grinding Wheel:

- A. If selecting a wheel not supplied with the machine, refer to a wheel speed chart to insure that the speed is correct for the wheel shape and size. (Please contact a grinding wheel dealer for this information).
- B. Supplied is a Diamond wheel suitable for HSS and carbide grinding. We also recommend that you use a 5 " flared cup, aluminum oxide, grinding wheel. The best grade is vitrified bonded 60 grit.
Dress the wheel with a dressing stick. Dish the face about 10 °, and smooth the periphery and your wheel is ready to work.
- C. Check grinding wheel to ensure the wheel is not cracked.
- D. Never alter the bore of the grinding wheel or force a wheel into spindle.
- E. Apply one clean, smooth blotter on each side of the wheel under each flange.
- F. Stand away from the front and the back of the wheel when first starting the grinding wheel. Before commencing to grind, run the wheel for at least one minute to test the wheel.
- G. Always store the grinding wheel at a dry and moderate temperature place.
- H. Please follow the instruction of the mounting and dressing of the grinding wheel in this manual.
- 1. Do not wear Rings, Wrist Watches, or Loose Long-Sleeve shirts when operating this machine.

4-2 Wheel Dressing

1. For an aluminium Oxide wheel you can use a dressing stick to manually dress the edge of the cup wheel with a sharp 10 ° angle. This should be done before using the machine,
2. The othe method is to use a diamond dresser to dress the wheel. The proce dures as below.
 - (1) Lower the wheelhead until the spindle center is slightly higher the diamond nib.
 - (2) Mount the dividing attachment on the table and insert the lathe tool holder. Secure the diamond dresser using the clamp screws. Tilt the diamond to an angle of 85 degrees to the wheel to be dressed.
 - (3) Crossfeed the table until the diamond nib is within 1mm of the wheel. Start the spindle, and lower the head until you hear the diamond just touch the wheel. Traverse the table slowly across the wheel to dress it.
NOTE! The down feed rate each time should not be over 0.001 “. Heavy cuts will dislodge the diamond.
Dressing will allow the periphery of the wheel to be concentric to the spindle and will help balance the wheel and remove vibration.
 - (4) Re-sharpen the cutting surface of the grinding wheel frequently or when the finish is poor

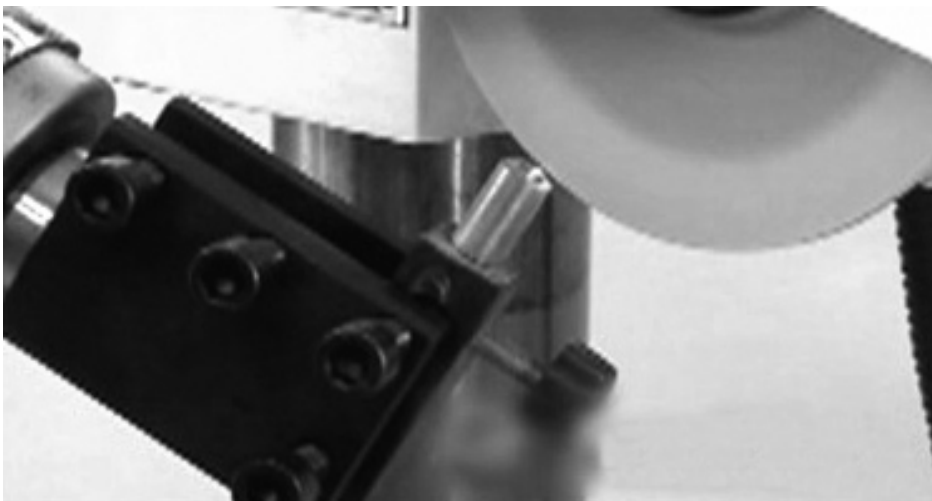

4. OPERATING INSTRUCTION

4-3 Cutting Tool Instruction

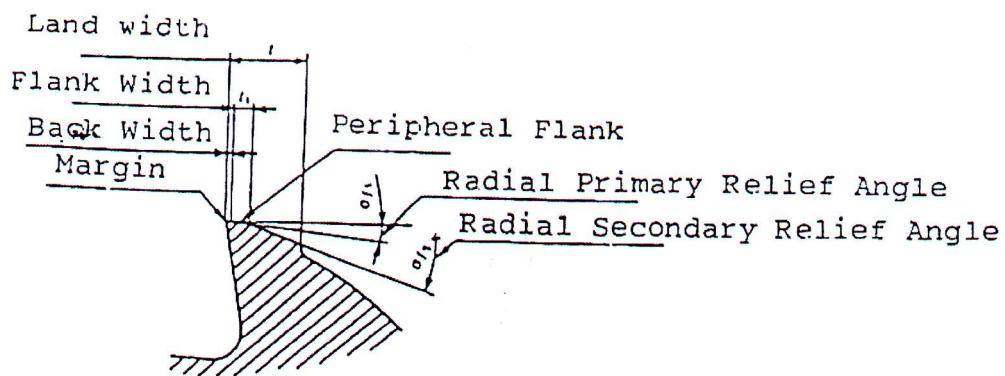
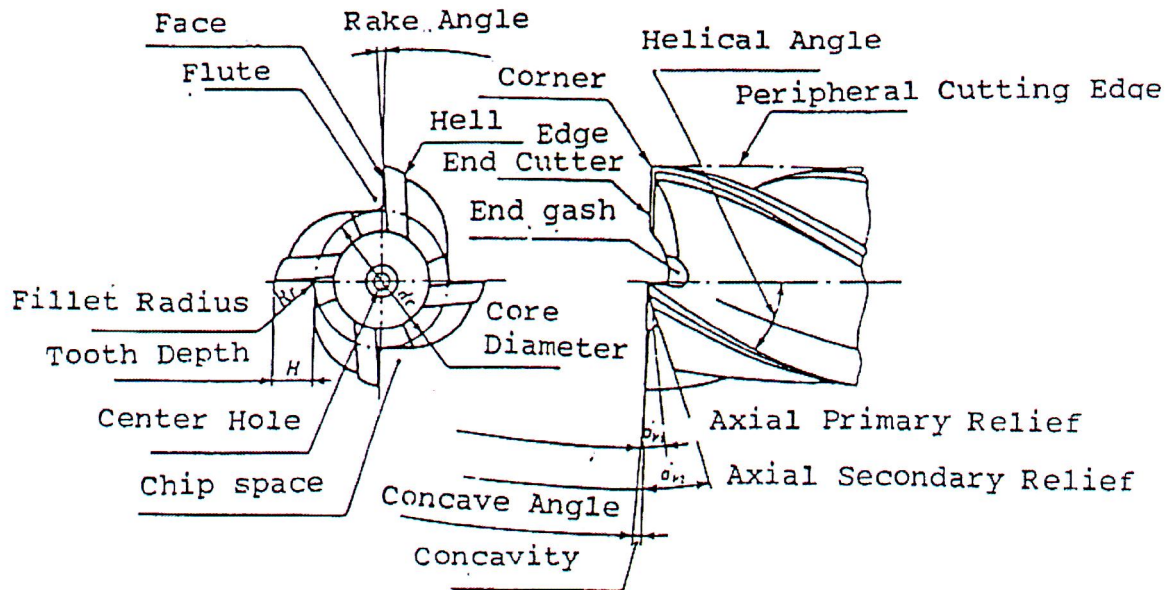

END MILL

4. OPERATING INSTRUCTION

4-4 Basic Setting for the Cutter Grinding

A .Sharpening High-Speed Steel And Cast Alloy Multi-Tooth Cutters

The working efficiency of a cutter is determined by the keenness of its cutting edges. When the cutting edges become dull, the cutter must be re-sharpened. A dull cutter will produce a poor finish surface. Frequently re-sharpen the cutter, and the cutter will be maintained in good working condition.

Regular re-sharpening the cutter, insures only a very small amount of material is taken of the teeth to restore its keen cutting edges. Cutters and Reamers are usually re-sharpened on the tool and cutter grinder using the accessories. The universal cutter grinder as its Name says, allows for various kind of tools, to be ground on this grinder.

a. Suggestion of the grinding wheels.

Usually a soft grade of grinding wheel is used to allow the free cutting action and avoid overheat being generated at the cutting edges. If the grinding wheel is too soft, its rapid wear makes it difficult to keep a true cylinder or to produce a keen cutting edge.

Usually an aluminum oxide (grain size 46 or 60) medium soft grade (J-L) structure 5-8 verified bonded wheel is used.

For best results when the cutting edge just needs to be made keen again is to use a diamond cup wheel. This is also is used for finishing or when the cutter teeth material is carbide tipped.

OPERATING INSTRUCTION

B. Relief Angles.

a. Relief Angle.

The relief is defined as the amount of stock removed from the tooth behind the cutting edge, so the cutter can cut freely clear the material after the cutting edge touches the work piece.

The relief Angle is very important for a cutter. If the angle is too small a drag force will be generate, when the tooth is ground. If the angle is too large, then rapid wear will occur at the cutting edge and it will tend to chatter when cutting. Preference should be given to the smaller relief angles rather than the larger relief angles. The larger relief angles will not cut accurately while the smaller angles still will work accurately.

The correct relief angle is determined by a number of factors. It is usually determined mainly by the type and size of the cutter and the hardness of the material to be cut. For example, to machining soft materials such as brass, the relief angle can be larger than what is required for machining hard materials, such as cast iron or steel. The relief angle of small diameter cutters should be larger. The proper relief angle must be determined by results. If the Relief Angle on the cutter has given you a good result it should be recorded for future reference. The general ranges of relief angles for typical tools and materials are listed below.

| Cutter | Tool Material | Work Material | | |
|---------------------------------------|---------------------|---------------|------------|-------------|
| | | Steel | Cast Iron | Non Ferrous |
| Peripheral or O.D. Cutting Edge | High Speed Steel | 5 ° - 10 ° | 5 ° - 10 ° | 7 ° - 12 ° |
| | Cast Alloys | 4 ° - 6 ° | 4 ° - 6 ° | 5 ° - 10 ° |
| | Cemented Carbide | 4 ° - 6 ° | 4 ° - 6 ° | 5 ° - 10 ° |
| | All | 1 ° - 4 ° | 1 ° - 4 ° | 2 ° - 7 ° |

Smaller diameter cutters require larger relief angles.

b. Land Width

The land is the flat area behind the cutting edge. Usually the width of the land is from 1/32 " to 1/16 " depend on the type and size of cutters.

Due to repeatedly grinding, the width of the land will become wider, and will cause the heel of the tooth to drag on the work.

To reduce the width of the land, the primary or secondary clearances are ground at the back of the cutting edge as shown in the relief angle of the tooth face. It is unnecessary to consider the relief angle, when grinding formed cutters and involute gear cutters which are resharpened by radial grinding, the cutting relief angle can be maintained unchanged.

Relief on New Cutter

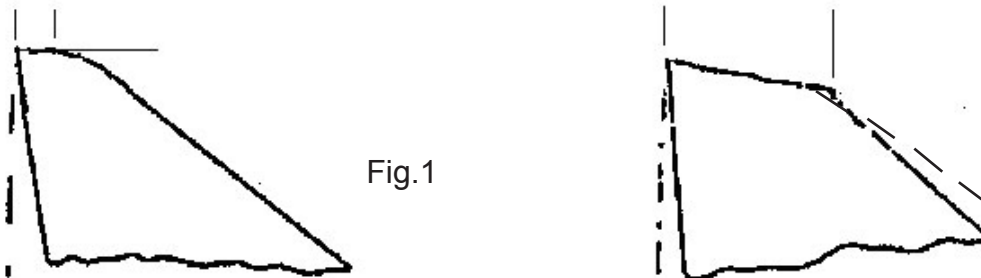

Fig. 1-Width of land increases with repeated sharpenings, causing interference at A Grind clearance angle as shown by dotted line to control width of land.

C. The determination of the relief angle.

In general, the setting of the relief angle is first to bring the center of the wheel and cutter, and the toothiest blade end, all on the same height, then raise or lower the wheelhead to the proper distance to get the desired relief angle. When the straight wheel is used the moving distance is determined by the diameter of the wheel. While the cup wheel is used the relief angle is determined by the diameter of the cutter.

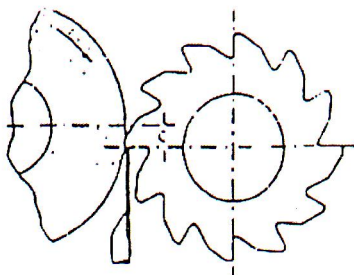

Fig. 2-Developing the relief angle when using a straight wheel

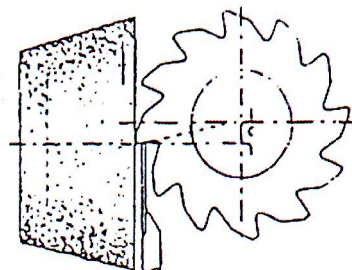

Fig. 3-Developing the relief angle when using a cup wheel

1. Toothrest setting, when the straight wheel is used.

As shown in fig .2 and fig .3 on the previous page, the center distance between the grinding wheel and cutter is determined by the relief angle. The setting method is as follows:

- (1) Select the appropriate grinding device for the job and mount it on the table. Set the center of the grinding wheel at the same height with the center of the cutter. This can be done by using a height gauge.
- (2) Mount the toothrest on the table. Set the blade end of the toothrest at the same height with the center of the cutter. This again can be done by using a height gauge.
- (3) Lower or raise the wheelhead the proper distance "C" to get the desired relief angle. (Lower or Raise is determined by the rotation direction). The distance "C" can be calculated by the following formula :

Wheel Diameter (inches) X relief angle (degrees) x 0.0087

Example : A 6 " diameter straight wheel is used.
The 7 degrees of the relief angle is required
find out $C = 6 \text{ " } \times 7 \text{ } \times 0.0087 = 0.565$

2. The setting of tooth rest, when the cup wheel is used:

As shown in Figure 6, a cup wheel is used to sharpen a cutter. The setting procedure of toothrest is as follows:

- (1) Mount the toothrest on the wheelhead. Set the blade end at the same height as the center of the cutter by height gage.
- (2) Raise or lower the wheelhead a distance C.
 $C = \text{cutter diameter} \times \text{Relief Angle} \times 0.0087$
Example : A 4 " cup wheel is used to grind a 3 " diameter cutter.
If the relief angle is 5 degrees, find out the distance C ?

$C = 5 \text{ } \times 3 \text{ " } \times 0.0087 = 0.130 \text{ "}$

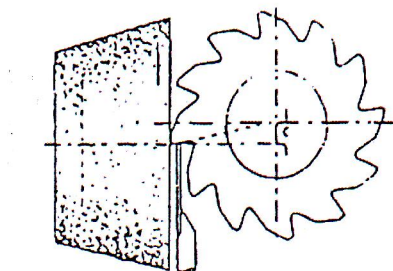

Fig.6

4-5 End Milling Grinding Device

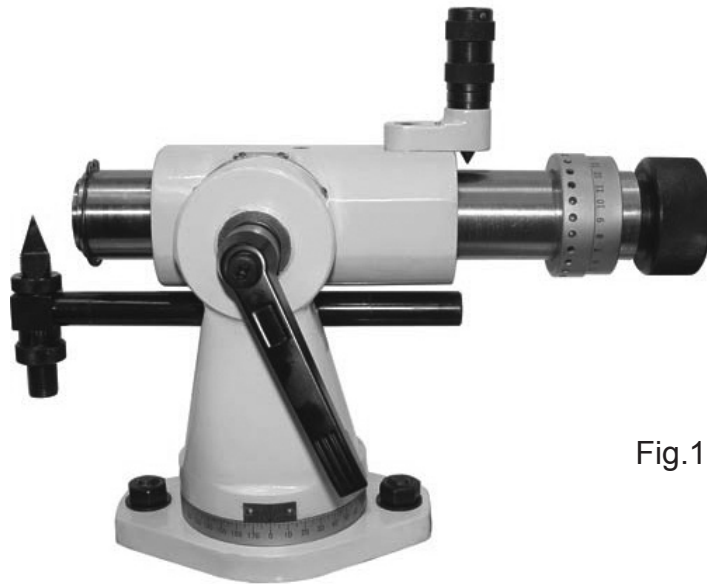

Fig.1

- (2) Select the suitable 5C collet to hold the shank of the End Mill or Slot Drill.
- (3) Put 5C collet into the sleeve along the key way, and then rotate the sleeve to lock it firmly as Figure 2.



Fig.2

- (4) Loosen the positioning screw of the tooth rest, and then adjust the tooth rest to the position where the cutter will not touch the pointer when the sleeve is pulled all the way back.

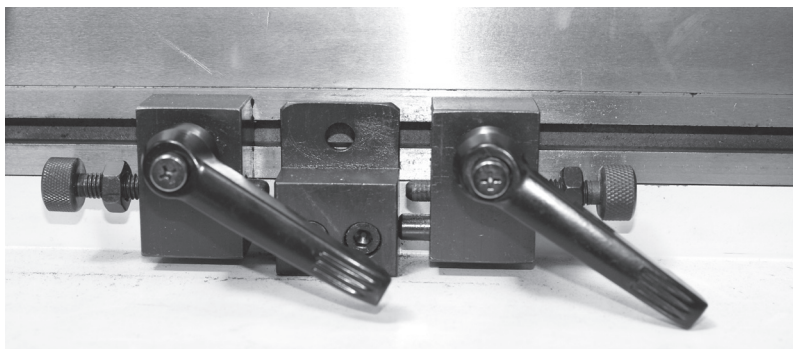

Fig.3

- (5) Rotate the tooth rest into the inner edge of the cutter blade, and position it as close as possible to the edge to be ground making sure that there is clearance and the finger will not touch the grinding wheel. Move the tooth rest until the tooth rest's upmost point and the cutter's center are on the same line horizontally



- (6) Adjust the grinding wheel's center a little higher than cutter's center point.
(7) Adjust the table position to have tooth rest's tip to just clear the wheel edge and then adjust lock knob that secures the tooth rest. Lock the table with the Micro Adjustment screws to secure the table-firmly in longitudinally plane.



- (8) Move the spindle backwards and then push the spindle forward for a distance of the length of the flutes to insure that all the flute length can be ground. Set the travel stops on the table so that the only travel will be the length of the flutes.

(10) Activate grinding motor in clockwise direction.

(11) Rotate crossfeed Handwheel till cutter touches the grinding wheel and generates sparks. Pull the sleeve slightly backwards, so that the cutter is ground. Rotate the sleeve as you move it forward and back naturally being sure to never let the cutter part from the tooth rest. Don't force the cutter to rotate.

NOTE! Always have the grinding wheel traveling in the direction that will push the cutter onto the tooth rest.

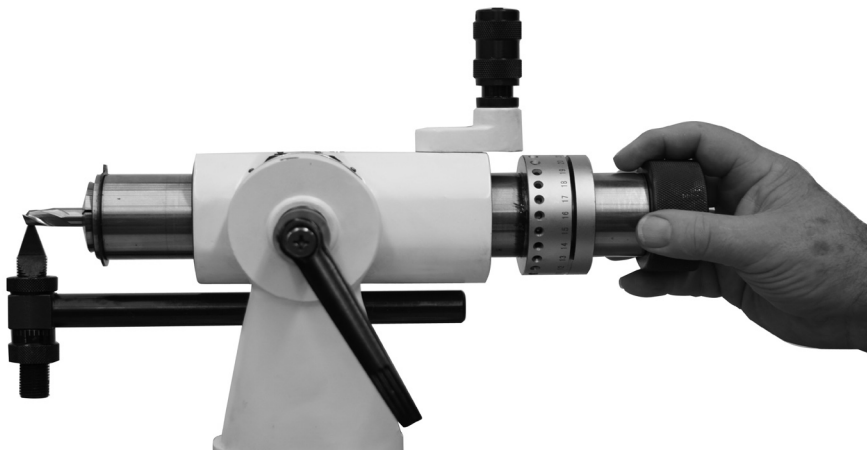

(12) When the flute is ground pull the cutter back away from the grinding wheel and off the tooth rest, and then rotate the sleeve to the next blade. Push the cutter forward to the start point and making sure that the flute is located on the tooth rest and start grindntg. After all the blades are ground, rotate the in-feed handwheel away from the grinding wheel. Turn off the motor when finished. Important :Do not let infeed amount exceed 0.025nun (0.001 ") each time

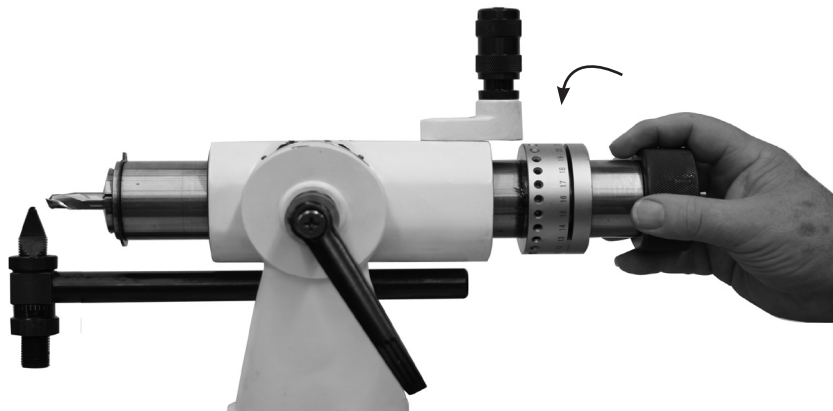

- (13) The decision whether to grind the 1st Relief Angle first or the 2nd Relief Angle First does not really matter, but when the decision is made all the blades have to be ground on that relief angle before grinding another Relief Angle.
Grinding method as step (9)—(12)
- (14) Width rate between 1st Relief Angle and the 2nd Relief Angle face is allowed on a ratio of around 1:2
- (15) After all the grinding steps are done release the cutter and the 5C collet from the sleeve. Tapping gently on the sleeve slightly could take off the 5C collet with less effort.

4-6 Cutter End Grinding,

- (1) Reset the end mill grinding attachment to the correct position.
- (2) Pull the sleeve all the way back, then adjust one of the flutes on the the tooth rest
- (3) Push the index ring forward. Insert the spring locating pin into the index plate according to the quantity of blades. Then remove the tooth rest, as Figure 10.



Fig.10

- (4) Adjust Grinding wheel's center to be on the same level of cutter's center .Grinding 1st Relief Angle the grinding wheel center should be lifted up by a short amount of distance-C as shown in Figure 11. Please refer to 3-4 (C) for calculation method of C.

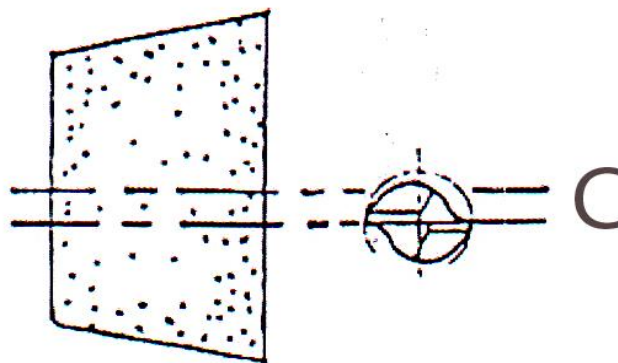

Fig.11

- (5) Loosen the End Mill Grinding Attachment so that it can be swiveled and adjust it 1° - 5° as Figure 12.



Fig. 12

- (6) Adjust the table and saddle to position the cutter end. Touch the first Relief Side and grinding wheel's edge slightly as Figure 13.

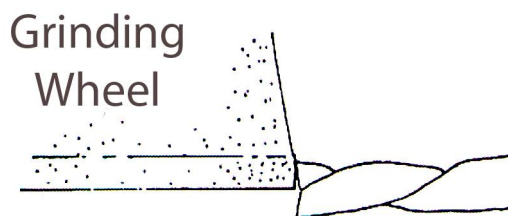

Fig. 13

- (7) Switch on the grinding wheel (clockwise), and rotate the crossfeed hand-wheel to start grinding. Rotate Knob B & C for feeding. Rotate B forward while C backwards. Fig. 14

Important : Never surpass the cutter's center during grinding. Do the in feed grinding after all the blades have been ground

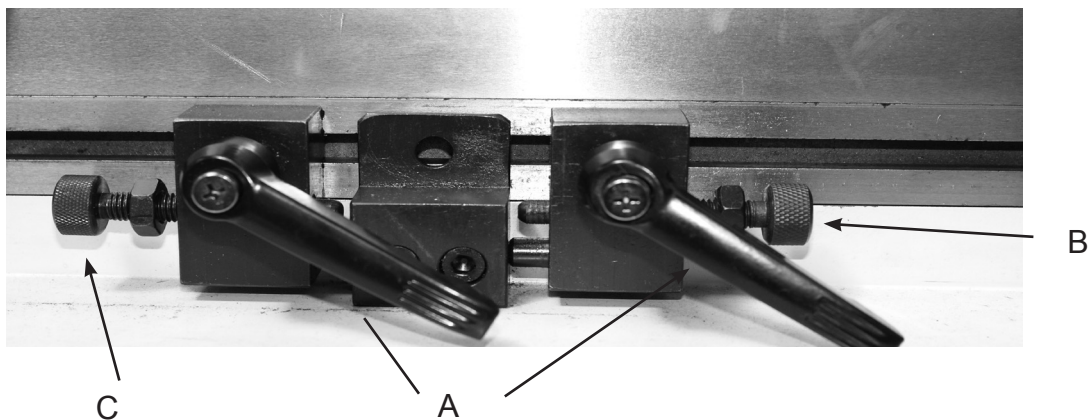

Fig. 14

(8) To grind another blade move the saddle away from the grinding wheel, release the index pin. Then rotate the index plate until the correctly selected index number appears, then insert the index pin into the slot beside the number. as Fig.15 Repeat steps (6)—(8) to grind each tooth.



Fig.15

(9) After grinding the 1st Relief Angle then do the grinding for 2nd Relief Angle, The lift level- C needed is shown as Figure 16.

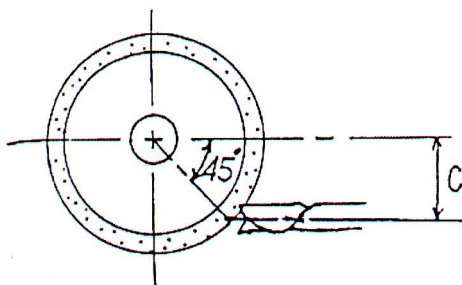

Fig.16

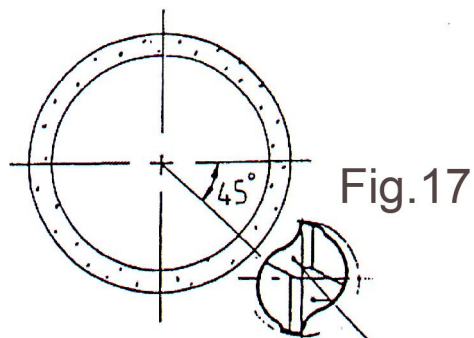

Fig.17
Axial Relief angle

- (10) Grinding methods as step (6)—(8).
- (11) The width rate between 1st Relief and 2nd Relief face is around 1:2.
- (12) The grinding angle of Axial Relief Angle is usually ground by forming a 45° angle between grinding wheel's center and cutter's center. After the 2nd Relief grinding is finished the rest could be ground by the same steps. Fig.17

5. Dividing Attachment

Supplied with 3 arbors 32mm, 22mm and lathe tool holder. The indexing plates allow of any angle to be set up to provide the desired result.



6. Drill Grinding Attachment

Operating instructions available for model number G196E



TM TOOLMASTER

Drill Grinding Attachment

To suit G198

OPERATION'S MANUAL



TM TOOLMASTER

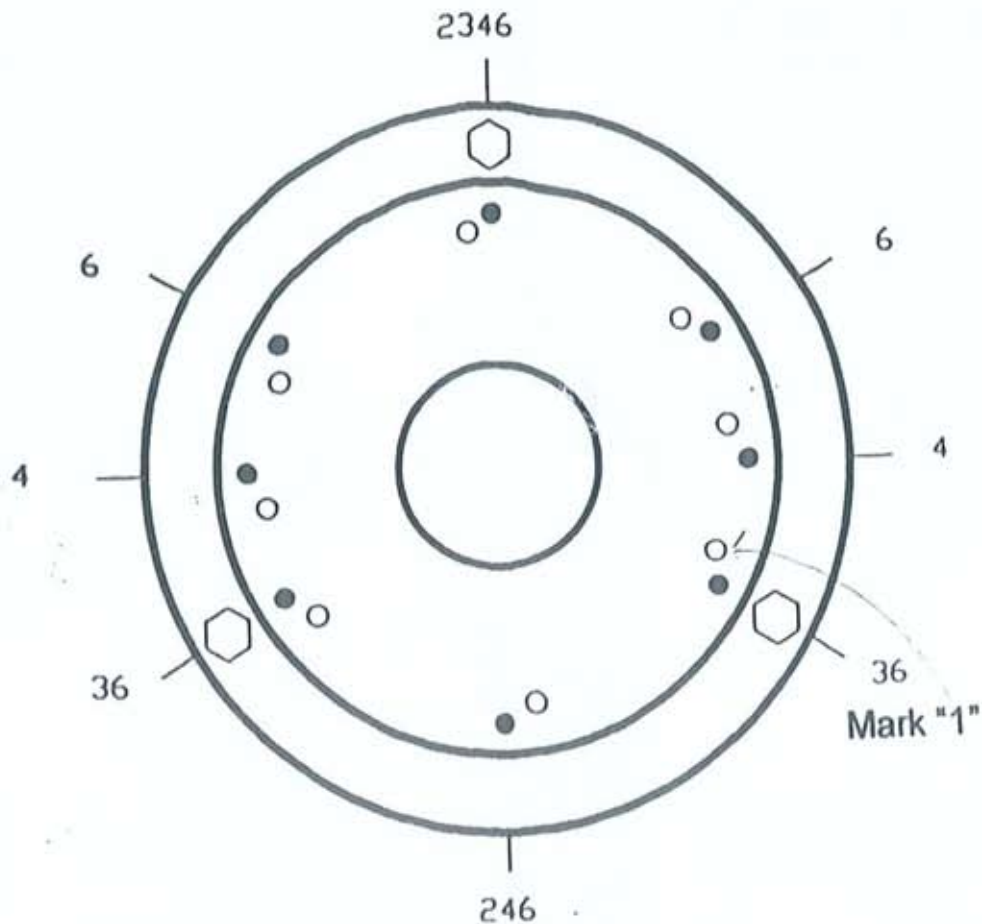

Before grinding any cutters, you must set the parts (No.14).

The numbers of the above picture show you the position to lock the parts (No.14) according to the flutes of the cutter.

For example:

1. If you would like to grind the drill 2 flutes, first you must lock the parts (NO.14) to the positions show NO.2.
2. If you would like to grind the tap 3 flutes, first you must lock the parts (NO.14) to the positions show NO.3.
3. Mark ● (outside) : Means the locations to screw the parts NO.14 for grinding the drills, step drills, Taps.
4. Mark ○ (inside) : Means the locations to screw the parts NO.14 for grinding the counter sink drills.
5. Mark "1" for grinding the single flute counter sink drills.

DRILLS & CUTTERS GRINDING ATTACHMENT

| No. | Ser. No. | Description | Q'ty | Specification | Remarks |
|-----|-----------|------------------|-------|---------------|---------|
| 1 | K003 | 6-jaw Chuck | 1 | 4" | |
| 2 | K001 | Main | 1 | | |
| 3 | K002 | Handwheel | 1 | | |
| 12 | K004 | Chuck Shaft | 1 | | |
| 13 | K005 | Double Cams | 1 set | | |
| 14 | K014 | Grinding needles | 6 | | |
| 15 | K013 | Diving Head | 1 | | |
| 16 | K011 | Spring | 1 | | |
| 44 | K009 | Adjusting Nuts | 2 | | |
| 50 | P007 | Key | 1 | | |
| 51 | P001 | Base Dish | 1 | | |
| 52 | P002/P003 | Main Column | 1 | | |
| 53 | T014 | Handle | 1 | M12*45L | |
| 54 | P005 | Graduated Dial | 1 | | |
| 55 | | Hexagon Nut | 1 | M12*55L | |
| 56 | K010 | Fixed Set | 1 | | |
| 57 | K008 | Screw | 1 | | |
| 58 | P006 | Graduated Dial | 1 | | |

1.) DRILL GRINDING:

GRINDING PREPARATION:

First, rid the rear bevel of the drill. This can make grinding process fast and not get heat. Besides, the course can not effect the hardness and the metal characteristic of the drill and reduce the expendable of grinding wheel. (see the following figure)



A. FIX THE DRILL

1. Insert the drill into No.1 chuck and make it 20mm jutting out of it. If the length of the drill is under 6mm, only make it 10mm jutting out of it.
2. Align the front clearance of the drill to the three-line position of No.1 chuck. (see the following figure) Then, lock the drill tightly.

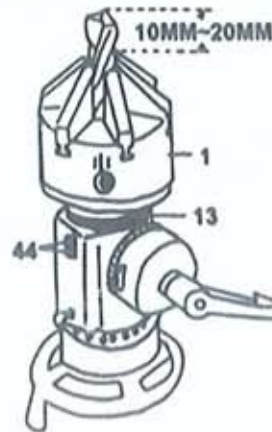

B. FIX THE ANGLE OF DRILL'S FOREPART

1. Adjust No.54 to the position you need, then lock No.55 tightly.

C. ADJUST LIP CLEARANCE ANGLE

1. There are two No.44 up the shaft, which can make the cam No.13 to move back and forward.
2. The more No.13 moves forward, the larger the lip clearance will be.
3. The more No.13 moves backward, the smaller the lip clearance will be.

D. PREPARE FOR GRINDING

1. Feed the drill's forepart continually till it is in the suitable position of the surface of the grinding wheel.
2. Turn on the power, revolve No.3 slowly by one hand when the grinding wheel starts (remember do not pause), and then do the feed by the other hand .Use slide rest to cross feed. Keep doing till the drill can touch the grinding wheel and make sparks.

E. SHARPEN THE DRILL

1. Turn off the power of the grinding wheel, loosen No.53 a little, then adjust the angle of chamfering, raise about $10^{\circ}\sim 15^{\circ}$.
2. There are No.56 and No.15 in the rear of the shaft. The radius is with 1-18 nicks between two sides of No.15. If the drill has two-fluted edge, you must find the equal positions of the two sides. For example, if you adjust the position to the "6" nick of one side, then you must rotate the radius to the other "6" nick of the other side. The foregoing method can grind each side correctly and grind the edge with the same height.
3. When the grinding procedure has been done or the angle needs to be changed, the cutting edge has to separate away from the grinding wheel. This is to avoid No.1 chuck getting down and touching the grinding wheel while No.53 lever was loosened.

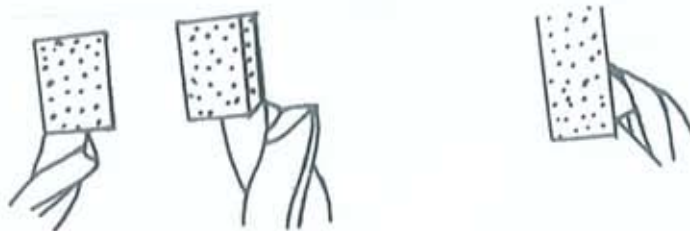

F. LIP GRINDING

1. Loosen No.55, then align No. 52 about the line of 90°.
2. Loosen No.53, raise No.1 about 3°.
3. Lock the drill into No.1, then align the position you need.
4. Loosen No.57 to make it beat back and forth, then set the drill to aim the external diameter of the grinding wheel. Start to grind by rotating No.3.

G. CHARPEN THE CENRTAL POINT

1. Loosen No.55, then align No. 52 about the line of 105°.
2. Insert No.57 into the groove of the main shaft. It makes the main shaft rotate, but does not beat back and forth.
3. Loosen No.53, raise No.1 about 12°.
4. Insert No.56 into No.15.(you can choose the number freely)
5. Use the longitudinal feed of the grinding wheel and the cross feed of the slide rest to control the feeding of sharpening the central point. Then change to the opposite of No.15 and grind it again. After that you can finish sharpening the two sides.

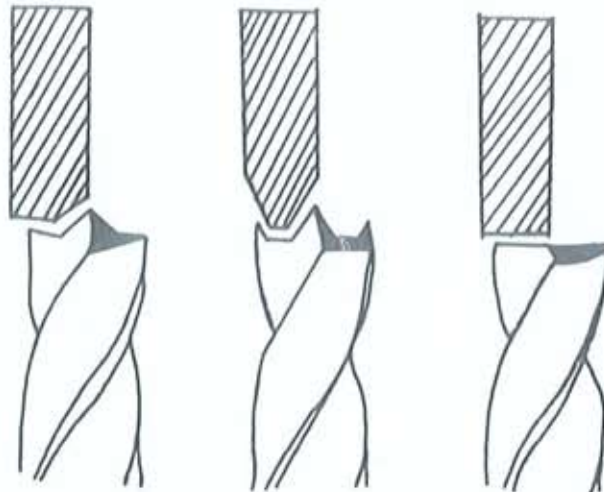

2.) GRIND STEP DRILL

- 1. Lock No.57 into No.12 to make the shaft rotate, but No.13 and No.14 do not rotate with the shaft.**
- 2. Push No.12 forward about 10mm, let the groove of No.12 be adjusted to No.57. Turn No.57 half into the groove. This is called cutting-off edge.**
- 3. If the second layer of cutting edge has to be ground as the first layer, it must equip with No.14 (two pieces), then align the second cutting edge. After that, you can finish step drill grinding.**
- 4. Please take the following figure for reference.**



3.) TAP GRINDING

1. The tap can be divided to be three-fluted edge, four-fluted edge, five-fluted edge and six-fluted edge, and etc.
2. If equip with three-fluted edge tape, has to change another set with No.14(3 pieces) and insert them into "3" nicks of No.1 chuck. Then, you can grind the three-fluted edge tap.
3. If equip with four-fluted edge tape, has to change another set with No.14 (4 pieces) and insert them into "4" nicks of No.1 chuck. Then, you can grind the four-fluted edge tap.
4. Use the same way to grind five-fluted and six-fluted edge.
5. Make the forepart of tap feeding into the proper position at the surface of grinding wheel. (see the following figure)
6. Revolve No.3 slowly by one hand when the grinding wheel starts (remember do not pause), and then do the feed by the other hand .Use slide rest to cross feed. Keep doing till the tap can touch the grinding wheel and make sparks.

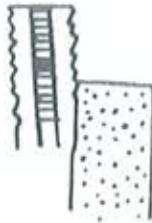

4.) END MILL LIP GRINDING

1. Turn off the grinding machine and loosen No.53 a little bit, and find the angle you need for grinding.
2. There are No.56 and No.15 in the rear of the shaft. The radius is with 1-18 nicks between two sides of No.15. If the end mill has two-fluted edge, you must find the equal positions of the two sides. For example, if you adjust the position to the "6" nick of one side, then you must rotate the radius to the other "6" nick of the other side. The foregoing method can grind each side correctly and grind the edge with the same height.
3. When the grinding procedure has been done or the angle needs to be changed, the cutting edge has to separate away from the grinding wheel. This is to avoid No.1 chuck getting down and touching the grinding wheel while No.53 lever was loosened.
4. If you grind the end mill with three-fluted edge, you should divide No.15 into three equal partitions.
5. If you grind the end mill with four-fluted edge, you should divide No.15 into four equal partitions.
6. The cutting edge of the end mill has three parts. First part, the cutting edge is smooth surface, the second part is oblique angle and the third part is central point. The three parts have their own angles. The angles can be changed whenever you need.

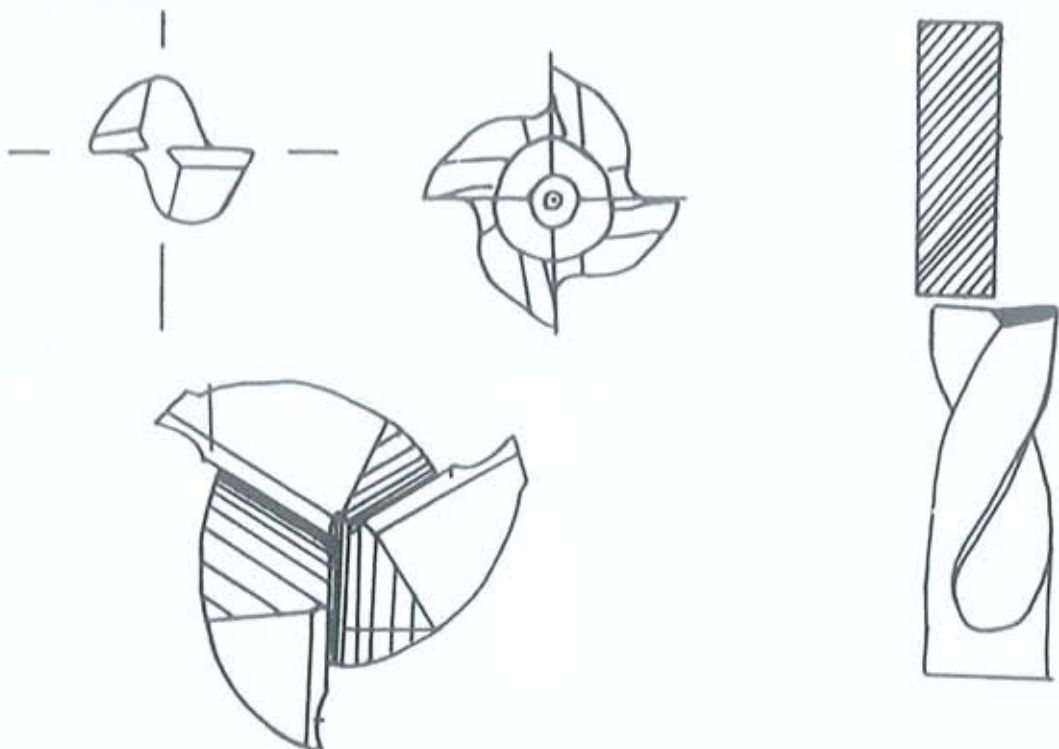

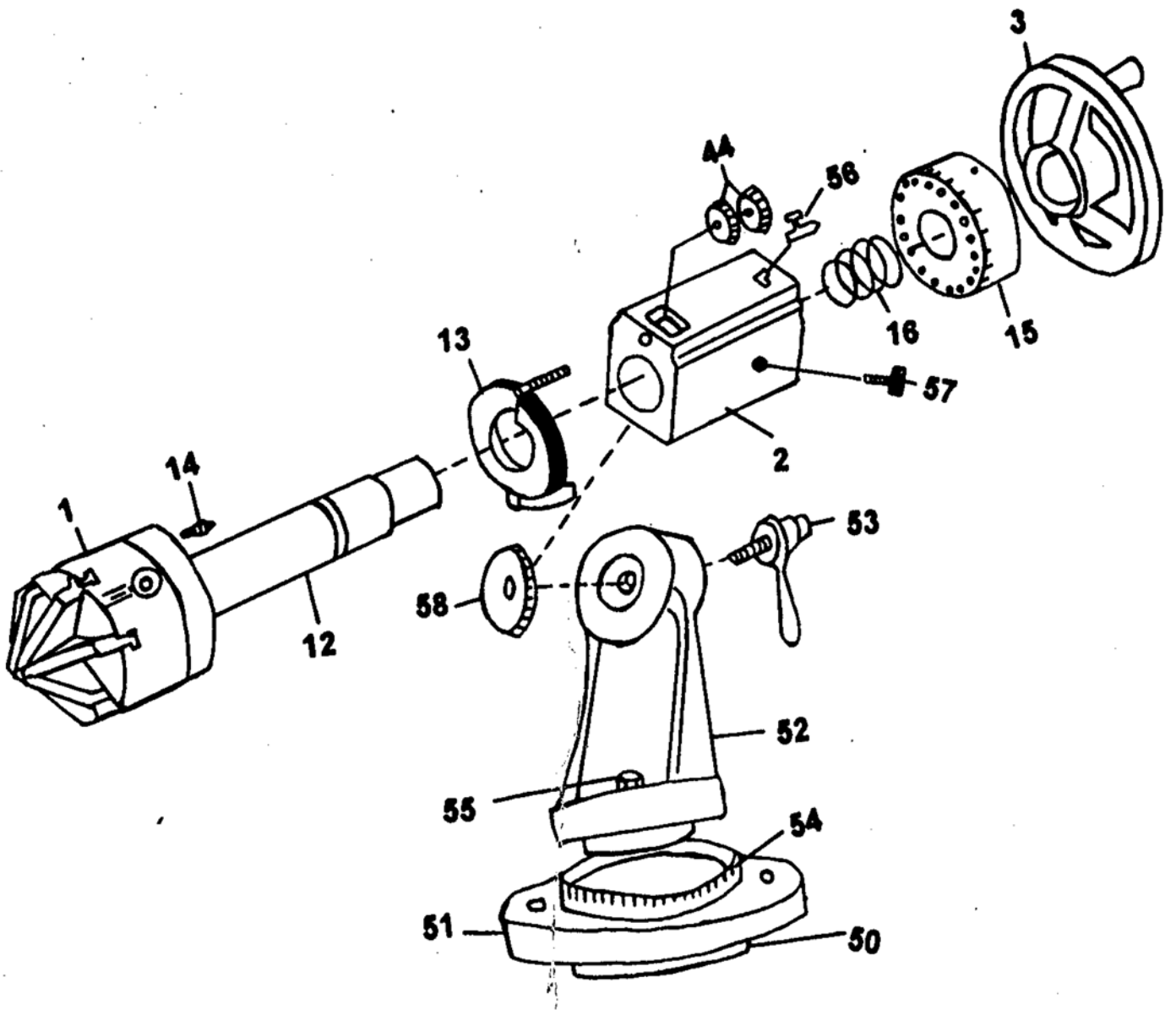

G198 Tool & Cutter Grinder

PARTS LISTS

TM6025Q

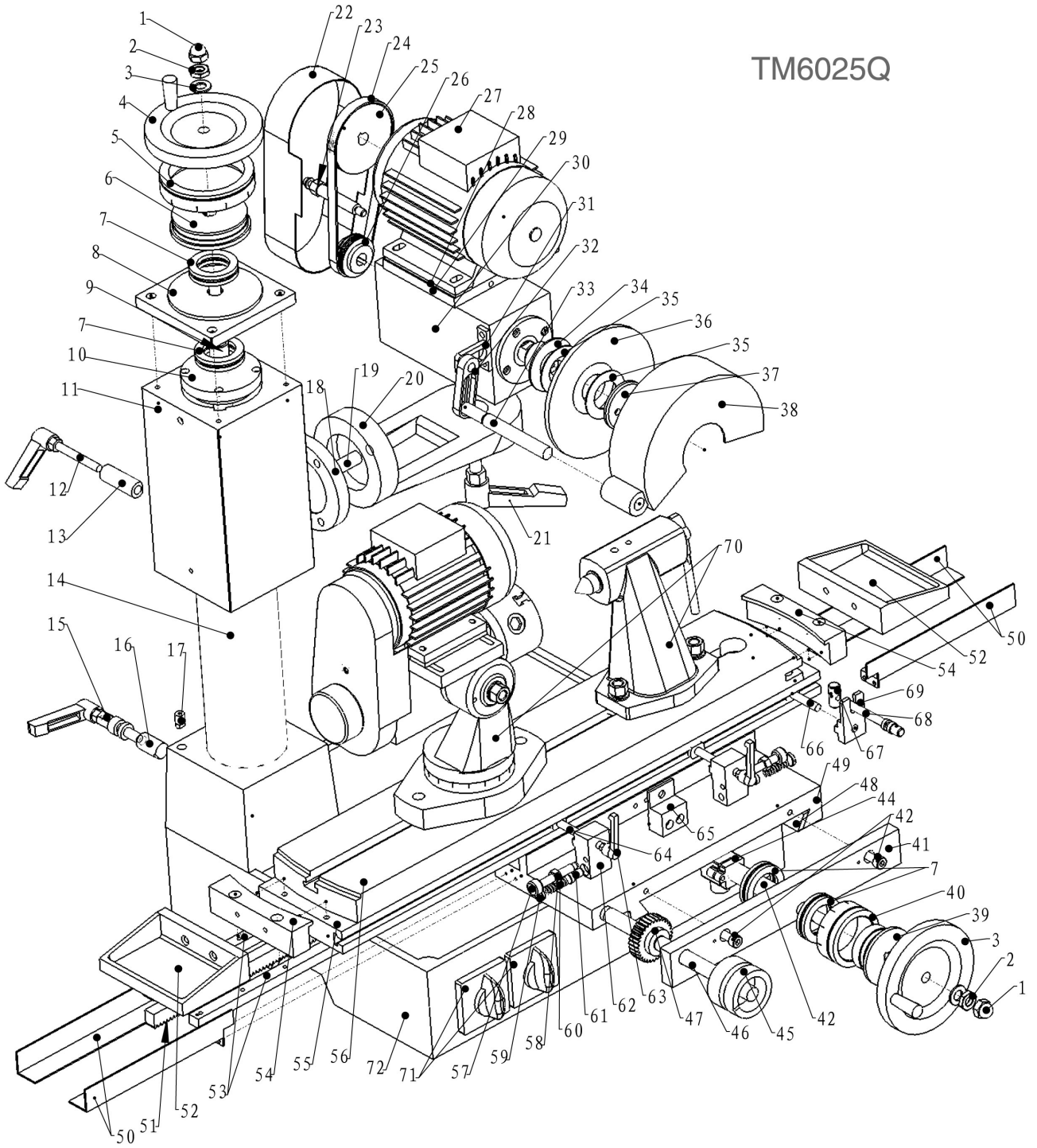

| No. | NAME |
|-----|-------------------------------------|
| 1 | cap nut M12 |
| 2 | hexagonal nut M12 |
| 3 | flat gasket 12 |
| 4 | standard spring gasket 12x125 |
| 5 | dial |
| 6 | bush ring |
| 7 | thrust ball bearing 51007 |
| 8 | spindle tube cover |
| 9 | elevating screw |
| 10 | screw base |
| 11 | spindle sleeve |
| 12 | adjustable locking handle M8x110 |
| 13 | spindle sleeve locking block |
| 14 | spindle |
| 15 | spindle locking block |
| 16 | spindle locking block |
| 17 | retaining axle |
| 18 | motor rotary plate |
| 19 | spindle screw |
| 20 | motor turning chassis |
| 21 | adjustable locking handle M12x30 |
| 22 | belt wheel cover |
| 23 | pole |
| 24 | poly V-belt |
| 25 | driving pulley |
| 26 | driven pulley |
| 27 | motor |
| 28 | shock absorption rubber gasket |
| 29 | motor junction board |
| 30 | high-speed grinding head assembly |
| 31 | bracket |
| 32 | junction board |
| 33 | grinding wheel cover shank |
| 34 | grinding wheel flange |
| 35 | paper gasket |
| 36 | Disc Grinding Wheel 32x150 |
| 37 | grinding wheel holddown disc |
| 38 | grinding wheel encloser |
| 39 | scale inner liner |
| 40 | scale circle |
| 41 | supporting plate |
| 42 | exagon socket head cap screws M8x2; |
| 43 | lead screw |
| 44 | Nut |
| 45 | handwheel |

| | |
|----|----------------------------------|
| 46 | handwheel axle |
| 47 | gear |
| 48 | inlaid strip |
| 49 | cross slide platform |
| 50 | dustproof board |
| 51 | gear |
| 52 | encloser |
| 53 | Linear Guide |
| 54 | pressure plate |
| 55 | Operating Table |
| 56 | rotary worktable |
| 57 | support-locking bolt |
| 58 | hexagonal nut M8 |
| 59 | adjustable bolt |
| 60 | Compressed Spring |
| 61 | positive stop part |
| 62 | spring positive stop |
| 63 | adjustable locking nut handle M8 |
| 64 | T-shaped screw |
| 65 | locking base |
| 66 | T-shaped screw |
| 67 | copper nut |
| 68 | small size lead screw |
| 69 | stand |
| 70 | grinding machine accessories |
| 71 | Power Switch |
| 72 | base |

Electrical Description

The electrical system of the grinding machine includes a 3/4HP (0.55KW) grinding motor, motor of head holder, control switch, and connecting cables. And its starting and stopping are controlled by the switch. The power of the electrical motor of the machine is 380V, 50Hz, 2800r/min. (110V/220V 60Hz is optional) The lead wire of the head holder motor is equipped with an aviation plug to facilitate operation.

The power supply should be the same with the requirements of the motor. It must be reliably earthed. A leakage protector is necessary!

Figure of Wiring the Machine Tool is as shown in the following:

